



RIDLEY



#BETOUGH
RIDLEY-BIKES.CH

#BETOUGH
2017

#BETOUGH

RIDLEY 2017

Wir fahren. Wir fahren am Limit. Ohne uns zu beschweren. Wir ziehen durch. Regen hält uns nicht auf. Je kräftiger uns der Wind ins Gesicht weht, desto stärker werden wir. Kopfsteinpflaster macht uns nichts aus, wir fahren nur noch schneller darüber. Wir erobern Berge und fahren nicht aussen herum. Es geht uns um die Ehre. Fahrräder sind die Mittel auf dem Weg zu unseren Zielen. Wir machen sie dreckig. Wir polieren sie auf Hochglanz. Wir sind bescheiden. Unsere Beine sprechen für uns. Taten sagen mehr als Worte. Die innere Stärke treibt uns an. Wir sind entschlossener und engagierter als unsere Mitmenschen. Wir konkurrieren nicht mit anderen, sondern mit uns selbst. Wenn wir hinfallen, stehen wir wieder auf. Wir halten erst an, wenn wir unser Ziel erreicht haben.



Nous roulons. Nous roulons de façon soutenue. Nous ne nous plaignons pas. Nous nous battons. La pluie ne nous arrête pas. Plus le vent souffle, plus nous gagnons en force. Les pavés ne nous décontenancent pas, ils nous poussent à accélérer. Nous n'évitons pas les montagnes, nous allons les conquérir. L'honneur est essentiel. Nos vélos nous aident à atteindre nos objectifs. Nous les salissons. Nous les faisons briller de mille feux. Nous sommes humbles. Nos jambes parlent pour nous. Nos actes sont plus parlants que nos mots. Notre force intérieure nous donne de l'élan. Nous sommes plus déterminés et dévoués que nos semblables. Nous ne sommes pas en compétition avec les autres mais avec nous-mêmes. Quand nous tombons, nous nous remettons en selle. Nous ne nous arrêtons pas avant d'avoir atteint notre objectif.



FASTTECH

RIDLEY 2017

Ridley hat seine patentierten Fast Technologies zwar schon 2010 entwickelt, verbessert diese aber immer noch stetig. Unsere Aero- und TT-Räder sind alle mit einigen oder sogar sämtlichen der folgenden Technologien ausgestattet, um die aerodynamische Effizienz und die Gesamtleistung des Fahrrads zu maximieren.

Ridley a développé ses Fast Technologies brevetées dès 2010 et ne cesse de les améliorer encore aujourd'hui. Afin d'augmenter l'efficacité aérodynamique ainsi que les performances des vélos, nos roues Aero et TT sont toutes équipées de certaines, voire même de l'ensemble, des technologies suivantes.

F-Seat Stays

Unsere neueste technische Innovation, die F-Seat Stays, setzen die Sitzstreben weiter unten an das Sitzrohr, sodass sie aus dem laminaren Luftstrom oben am Rahmen und hinter die Verwirbelungen kommen, die von den rotierenden Beinen erzeugt werden.

Notre toute dernière innovation technologique, F-Seat Stays, déplace les fourches de la selle plus bas sur le tube de selle de manière à ce qu'elles sortent du courant laminaire en haut du cadre et derrière l'air en mouvement du à la rotation des bras de fourche.



F-Split Fork

Diese patentierte Radgabel leitet Luft um und durch die Gabel, damit das Rad mit weniger Widerstand drehen kann. Das Ergebnis ist eine Effizienzsteigerung der Rahmen-Rad-Kombi um 7 %.

Cette fourche brevetée guide l'air autour de et à travers la fourche pour aider la roue à tourner avec moins de résistance. Résultat : la combinaison cadre-roue gagne 7 % d'efficacité.



F-Surface Plus

Bei dieser Fast Technology sorgt ein kleiner, gegossener Kanal im Unterrohr und Sitzrohr für einen eher laminaren Luftstrom um den Fahrradrahmen, ohne dabei die Seitenwindstabilität zu beeinträchtigen (was normalerweise mit aerodynamischen Rahmen einhergeht).

Grâce à cette Fast Technology, un petit encart moulé dans le tube inférieur et la tige de selle crée un courant laminaire autour du cadre sans nuire à la stabilité au vent latéral (ce que l'on retrouve généralement sur les cadres de vélos aérodynamiques).

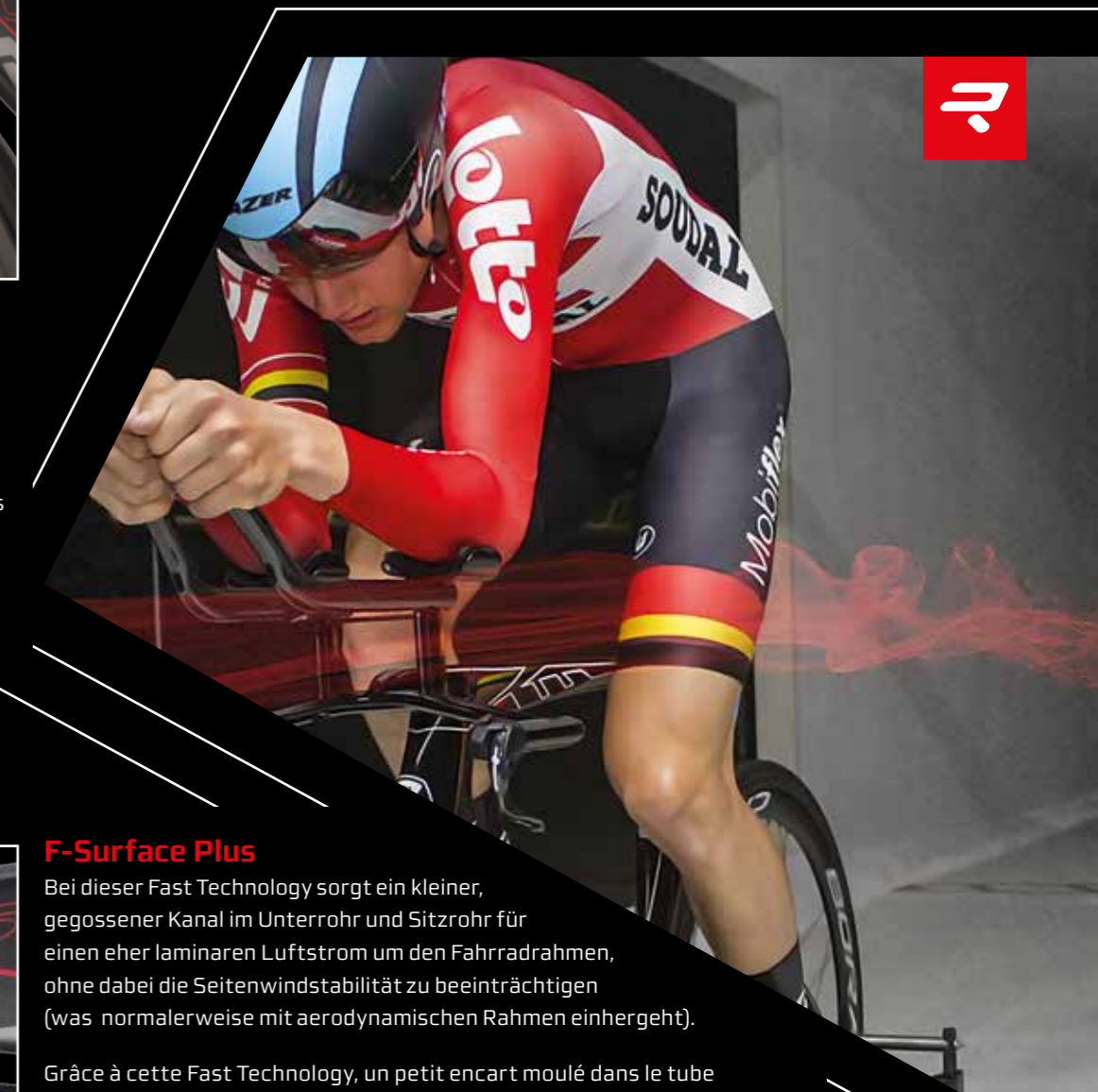



ROAD | STIFFNESS TO WEIGHT



HELIUM SLX ab CHF 5795.-



HELIUM X ab CHF 3095.-

ROAD | AERO



NOAH SL ab CHF 4495.-



NOAH SL DISC ab CHF 4695.-



NOAH ab CHF 3195.-

ROAD | ENDURANCE



FENIX SL ab CHF 2695.-



FENIX SL DISC ab CHF 2995.-



FENIX DISC ab CHF 2895.-

ROAD | WOMEN



LIZ SL ab CHF 2595.-



LIZ ab CHF 2395.-

ALLROAD



X-TRAIL DISC ab CHF 2895.-

CROSS



X-NIGHT ab CHF 2395.-



X-NIGHT DISC ab CHF 2595.-

TIMETRIAL/TRIATHLON



DEAN ab CHF 5195.-

Alle Preisangaben in Schweizer Franken (CHF).
Tous les prix indiqués sont en franc suisse (CHF)



HELIUM SLX

Stiffness to Weight

größen/tailles XS, S, M, L

rahmengewicht/poids cadre ca. 750g

gewicht/poids ab/dès 6.4kg

vorbau, lenker, stütze

potence, guidon, tige de selle

3T Pro +0.-

3T Team/LTD Stealth Carbon +500.-

Lenker/guidon 3T Aeronova Team Stealth +150.-

laufräder/roues

Fulcrum Racing Zero +0.-

DT Swiss RC 46 Spline H +375.-

Fulcrum Racing Zero NITE +400.-

Zipp 303 Carbon +1350.-

bereifung/pneus

Michelin Pro 4 Race 23mm Black +0.-

Schwalbe One V-Guard 23mm Black +0.-

Continental GP 4000S II 23mm Black +0.-

Continental GP 4000S II 25mm Black +0.-

sattel/selle

Selle Italia SLR Ti +0.-

Selle Italia Lady Flow +0.-

Selle Italia SLR Flow +0.-

fi'zi:k Arione R5 Wing Flex +0.-

fi'zi:k Arione Donna Wing Flex +0.-



carbon/grey/red 2016 | CHF - 300.-

DURA-ACE
7595.- Di2
6195.-

SHIMANO ULTEGRA
5795.- Di2
4995.-

SRAM RED
6995.- eTap
5995.-

NEW





HELIUM X

Stiffness to Weight

größen/tailles XS, S, M, L

rahmengewicht/poids cadre ca. 880g

gewicht/poids ab/dès 7.0kg

vorbau, lenker, stütze

potence, guidon, tige de selle

Ritchey HP Black +0.-

Ritchey WCS Wet Black +75.-

Lenker/guidon WCS Stream (only with WCS) +25.-

laufräder/roues

DT Swiss R 32 Spline +0.-

Fulcrum Racing Quattro +50.-

Fulcrum Racing 3 +200.-

Fulcrum Racing Zero +600.-

bereifung/pneus

Michelin Pro 4 Race 23mm Black +0.-

Schwalbe One V-Guard 23mm Black +0.-

Continental GP 4000S II 23mm Black +0.-

Continental GP 4000S II 25mm Black +0.-

sattel/selle

Selle Italia SLS Flow +0.-

Selle Italia Lady Flow +0.-

fi'zi:k Arione Donna Wing Flex +0.-

fi'zi:k Arione R5 Wing Flex +25.-

Selle Italia SLR Ti +25.-



UD-carbon/grey/red 2016 | CHF -200.-



white/black 2016 | CHF -200.-

sumano
ULTEGRA
4195.- Di2
3395.-

sumano **105**
3095.-

FORCE22
3695.-

NEW





NOAH SL

Aero

größen/tailles XS, S, M, L

rahmengewicht/poids cadre ca. 950 g

gewicht/poids ab/dès 6.9 kg

vorbau, lenker/potence, guidon

3T Pro +0.-

3T Team/LTD Stealth Carbon +375.-

Lenker/guidon 3T Aeronova Team Stealth +150.-

laufräder/roues

Fulcrum Racing Quattro +0.-

Zipp 30 Course +600.-

Fulcrum Racing Quattro Carbon +1200.-

Zipp 404 Carbon +1900.-

bereifung/pneus

Michelin Pro 4 Race 23mm Black +0.-

Schwalbe One V-Guard 23mm Black +0.-

Continental GP 4000S II 23mm Black +0.-

Continental GP 4000S II 25mm Black +0.-

sattel/selle

Selle Italia SLR Ti +0.-

Selle Italia Lady Flow +0.-

Selle Italia SLR Flow +0.-

fi'zi:k Arione R5 Wing Flex +0.-

fi'zi:k Arione Donna Wing Flex +0.-

DURA-ACE
6995.- Di2
5695.-

SHIMANO ULTEGRA
5295.- Di2
4495.-

SRAM RED
6395.- eTap
5395.-





NOAH SL DISC

Aero

größen/tailles XS, S, M, L

rahmengewicht/poids cadre ca. 1070g

gewicht/poids ab/dès 7.7 kg

vorbau, lenker/potence, guidon

3T Pro +0.-

3T Team/LTD Stealth Carbon +375.-

Lenker/guidon 3T Aeronova Team Stealth +150.-

laufräder/roues

Fulcrum Racing 5 Disc +0.-

DT Swiss R23 Spline Disc +0.-

Zipp 30 Course Disc +500.-

Fulcrum Racing Quattro Carbon Disc +1100.-

bereifung/pneus

Michelin Pro 4 Race 23mm Black +0.-

Schwalbe One V-Guard 23mm Black +0.-

Continental GP 4000S II 23mm Black +0.-

Continental GP 4000S II 25mm Black +0.-

sattel/selle

Selle Italia SLR Ti +0.-

Selle Italia Lady Flow +0.-

Selle Italia SLR Flow +0.-

fi'zi:k Arione R5 Wing Flex +0.-

fi'zi:k Arione Donna Wing Flex +0.-

DURA-ACE

7295.- Di2

5895.-

SUMMO
ULTEGRA

5495.- Di2

4695.-

NEW





NOAH

Aero

größen/tailles XS, S, M, L
rahmengewicht/poids cadre ca. 1100g
gewicht/poids ab/dès 7.5 kg

vorbau, lenker, stütze
potence, guidon, tige de selle
Ritchey HP Black +0.-
Ritchey WCS Wet Black +50.-
Lenker/guidon WCS Stream (only with WCS) +25.-

laufräder/roues
DT Swiss R 32 Spline +0.-
Fulcrum Racing Quattro +50.-
Fulcrum Racing 3 +200.-
Fulcrum Racing Zero +600.-

bereifung/pneus
Michelin Pro 4 Race 23mm Black +0.-
Schwalbe One V-Guard 23mm Black +0.-
Continental GP 4000S II 23mm Black +0.-
Continental GP 4000S II 25mm Black +0.-

sattel/selle
Selle Italia SLS Flow +0.-
Selle Italia Lady Flow +0.-
fi'zi:k Arione Donna Wing Flex +0.-
fi'zi:k Arione R5 Wing Flex +25.-
Selle Italia SLR Ti +25.-



black/white

sumano ULTEGRA	sumano 105	FORCE2
4395.- Di2	3195.-	3795.-
3495.-		





FENIX SL

Endurance

größen/tailles XS, S, M, L
rahmengewicht/poids cadre ca. 1050g
gewicht/poids ab/dès 7.3kg

vorbau, lenker, stütze
potence, guidon, tige de selle
Ritchey HP Black +0.-
Ritchey WCS Wet Black +75.-
Lenker/guidon WCS Stream (only with WCS) +25.-

laufräder/roues
DT Swiss R 32 Spline +0.-
Fulcrum Racing Quattro +50.-
Fulcrum Racing 3 +200.-
Fulcrum Racing Zero +600.-

bereifung/pneus
Michelin Lithion 2 23mm Black +0.-
Michelin Lithion 2 25mm Black +0.-
Continental GP 4000S II 23mm Black +50.-
Continental GP 4000S II 25mm Black +50.-

sattel/selle
Selle Italia SLS Flow +0.-
Selle Italia Lady Flow +0.-
fi'zi:k Arione Donna Wing Flex +0.-
fi'zi:k Arione R5 Wing Flex +25.-
Selle Italia SLR Ti +25.-



carbon / red / white

sumano ULTEGRA	sumano 105	FORCE22
3795.- Di2	2695.-	3195.-
2995.-		





FENIX SL DISC

Endurance

größen/tailles XXS, XS, S, M, L
rahmengewicht/poids cadre ca. 1030g
gewicht/poids ab/dès 8.1 kg

vorbau, lenker, stütze
potence, guidon, tige de selle
Ritchey HP Black +0.-
Ritchey WCS Wet Black +75.-
Lenker/guidon WCS Stream (only with WCS) +25.-

laufräder/roues
DT Swiss R24 Spline Disc +0.-
DT Swiss R32 Spline Disc +100.-
Fulcrum Racing 5 Disc +200.-
Zipp 30 Course Disc +650.-

bereifung/pneus
Michelin Lithion 2 25mm Black +0.-
Continental GP 4000S II 25mm Black +50.-

sattel/selle
Selle Italia SLS Flow +0.-
Selle Italia Lady Flow +0.-
fi'zi:k Arione Donna Wing Flex +0.-
fi'zi:k Arione R5 Wing Flex +25.-
Selle Italia SLR Ti +25.-



SHIMANO
ULTEGRA
4195.- Di2
3295.-

SHIMANO **105**
2995.-

NEW



FENIX DISC

Endurance

größen/tailles XS, S, M, L

rahmengewicht/poids cadre ca. 1270g

gewicht/poids ab/dès 8.0kg

vorbau, lenker, stütze

potence, guidon, tige de selle

Ritchey Comp +0.-

Ritchey HP Black +25.-

laufräder/roues

DT Swiss R24 Spline Disc +0.-

Shimano RX31 Disc +50.-

DT Swiss R32 Spline Disc +100.-

Fulcrum Racing 5 Disc +150.-

bereifung/pneus

Michelin Lithion 2 23mm Black +0.-

Michelin Lithion 2 25mm Black +0.-

Continental GP 4000S II 23mm Black +50.-

Continental GP 4000S II 25mm Black +50.-

sattel/selle

Selle Italia SLS Flow +0.-

Selle Italia Lady Flow +0.-

fi'zi:k Arione Donna Wing Flex +0.-

fi'zi:k Arione R5 Wing Flex +25.-

Selle Italia SLR Ti +25.-

SHIMANO
ULTEGRA
4095.- Di2
3195.-

SHIMANO
105
2895.-





LIZ SL

Women

größen/tailles XS, S, M
rahmengewicht/poids cadre ca. 1010g
gewicht/poids ab/dès 7.4kg

vorbau, lenker, stütze
potence, guidon, tige de selle

Ritchey Comp Black	+0.-
Ritchey HP Black	+25.-

laufräder/roues

DT Swiss R32 Spline	+0.-
Fulcrum Racing Quattro	+50.-
Fulcrum Racing 3	+200.-
Fulcrum Racing Zero	+600.-

bereifung/pneus

Michelin Pro 4 Race 23mm Black	+0.-
Schwalbe One V-Guard 23mm Black	+0.-
Continental GP 4000S II 23mm Black	+0.-
Continental GP 4000S II 25mm Black	+0.-

sattel/selle

Selle Italia ZOO Lady	+0.-
Selle Italia Lady Flow	+0.-
fi'zi:k Arione Donna Wing Flex	+25.-

SHIMANO ULTEGRA	SHIMANO 105	SHIMANO FORCE22
3795.- Di2	2595.-	3195.-
2995.-		

NEW





LIZ

Women

größen/tailles XS, S, M
rahmengewicht/poids cadre ca. 1110g
gewicht/poids ab/dès 7.7kg

vorbau, lenker, stütze
potence, guidon, tige de selle
Ritchey Comp Black +0.-

laufräder/roues
Fulcrum Racing 7 +0.-
Shimano RS21 Black +50.-
Shimano RS21 White +50.-
Fulcrum Racing Quattro +150.-

bereifung/pneus
Michelin Lithion 2 23mm Black +0.-
Michelin Lithion 2 25mm Black +0.-
Continental GP 4000S II 23mm Black +50.-
Continental GP 4000S II 25mm Black +50.-

sattel/selle
Selle Italia ZOO Lady +0.-
Selle Italia Lady Flow +0.-
fi'zi:k Arione Donna Wing Flex +25.-

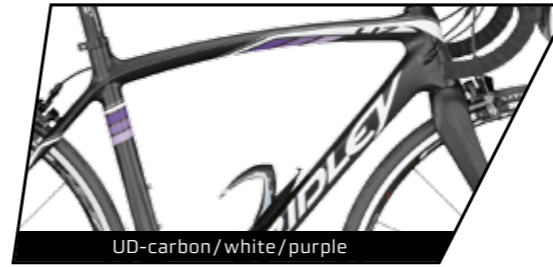

UD-carbon/white/purple

SHIMANO ULTEGRA	SHIMANO 105	FORCE22
2695.-	2395.-	2895.-





X-TRAIL DISC

Allroad

größen/tailles XS, S, M, L
rahmengewicht/poids cadre ca. 1030g
gewicht/poids ab/dès 8.2 kg

vorbau, lenker, stütze
potence, guidon, tige de selle
Ritchey HP Black +0.-
Ritchey WCS Wet Black +75.-

laufräder/roues
Fulcrum Racing 5 Disc +0.-
DT Swiss R23 Spline Disc +50.-
DT Swiss R32 Spline Disc +50.-

bereifung/pneus
Continental GP 4000 II 25mm +0.-
Schwalbe Sammy Slick +0.-
Continental GP 4000 II 28mm +50.-

sattel/selle
Selle Italia SLS Flow +0.-
Selle Italia Lady Flow +0.-
fi'zi:k Arione Donna Wing Flex +0.-
fi'zi:k Arione R5 Wing Flex +25.-
Selle Italia SLR Ti +25.-

SHIMANO
ULTEGRA
4295.- Di2
3495.-
3195.- Flatbar

SHIMANO **105**
3195.-
2895.- Flatbar





X-NIGHT

Cross

größen/tailles XS, S, M, L
rahmengewicht/poids cadre ca. 1020g
gewicht/poids ab/dès 7.9 kg

vorbau, lenker, stütze
potence, guidon, tige de selle

Ritchey HP Black	+0.-
Ritchey WCS Wet Black	+75.-

laufräder/roues

Fulcrum Racing 7	+0.-
Shimano RS21 Black	+50.-
Fulcrum Racing Quattro	+150.-
Fulcrum Racing 3	+325.-

bereifung/pneus

Schwalbe Sammy Slick	+0.-
Michelin Cross Mud 2	+50.-

sattel/selle

Selle Italia SLS Flow	+0.-
Selle Italia Lady Flow	+0.-
fi'zi:k Arione Donna Wing Flex	+0.-
fi'zi:k Arione R5 Wing Flex	+25.-
Selle Italia SLR Ti	+25.-

SHIMANO ULTEGRA	SHIMANO 105
2795.-	2495.-
2595.- Flatbar	2395.- Flatbar





black / red / grey

SHIMANO
ULTEGRA
3195.-
2895.- Flatbar

SHIMANO 105
2895.-
2595.- Flatbar

X-NIGHT DISC

Cross

größen/tailles XS, S, M, L, L
rahmengewicht/poids cadre ca. 980g
gewicht/poids ab/dès 8.4kg

vorbau, lenker, stütze
potence, guidon, tige de selle
Ritchey HP Black +0.-
Ritchey WCS Wet Black +75.-

laufräder/roues
DT Swiss R24 Spline Disc +0.-
DT Swiss R32 Spline Disc +100.-
Fulcrum Racing 5 Disc +150.-

bereifung/pneus
Schwalbe Sammy Slick +0.-
Michelin Cross Mud 2 +50.-

sattel/selle
Selle Italia SLS Flow +0.-
Selle Italia Lady Flow +0.-
fi'zi:k Arione Donna Wing Flex +0.-
fi'zi:k Arione R5 Wing Flex +25.-
Selle Italia SLR Ti +25.-





DEAN

Timetrial/Triathlon

größen/tailles XS, S, M, L
rahmengewicht/poids cadre ca. 1380g
gewicht/poids ab/dès 8.2kg

lenker/guidon
 Deda Kombi Kronos +0.-

vorbau/potence
 Ritchey WCS Wet Black +0.-
 Ritchey WCS Carbon +100.-

laufräder/roues
 Fulcrum Red Wind H. 50 +0.-
 Fulcrum Racing Quattro Carbon +350.-
 Zipp 404 Carbon +1000.-
 Zipp 808 Carbon +1350.-

bereifung/pneus
 Michelin Pro 4 Race 23mm Black +0.-
 Schwalbe One V-Guard 23 mm Black +0.-
 Continental GP 4000S II 23mm Black +0.-
 Continental GP 4000S II 25mm Black +0.-

sattel/selle
 fi'zi:k Ares TRI +0.-
 fi'zi:k Ares Tritone 5.5 +25.-

DURA-ACE	SHIMANO ULTEGRA	SRAM RED
7795.- Di2	6395.- Di2	7095.- eTap
6095.-	5195.-	6595.-



GEOMETRY

#BETOUGH

ROAD

	B	S	C'	D	E	F
HELIUM SLX/HELIUM X						
XS	480	530	525	130	74,0°	72,0°
S	510	545	545	145	73,5°	73,0°
M	540	575	565	175	73,0°	73,5°
L	570	602	585	205	72,5°	73,5°

NOAH SL/NOAH SL DISC/NOAH

XS	475	527	525	130	74,0°	72,0°
S	490	542	545	145	73,5°	73,0°
M	520	573	565	175	73,0°	73,5°
L	550	599	585	205	72,5°	73,5°

FENIX SL/FENIX SL DISC (XXS nur Disc)

XXS	450	507	515	107	75,0°	71,8°
XS	480	527	525	127	74,0°	72,0°
S	510	542	545	142	73,5°	73,0°
M	540	573	565	172	73,0°	73,5°
L	570	599	585	202	72,5°	73,5°

FENIX DISC

XS	480	530	525	130	74,0°	72,0°
S	510	545	545	145	73,5°	73,0°
M	540	575	560	175	73,0°	73,5°
L	570	602	585	205	72,5°	73,5°

ROAD

	B	S	C'	D	E	F
LIZ SL						
XS	450	507	515	107	75,0°	73,0°
S	510	542	545	142	73,5°	73,0°
M	540	573	565	172	73,0°	73,5°

LIZ

XS	450	485	500	110	75,5°	70,5°
S	490	500	515	130	75,0°	71,0°
M	520	522	530	155	74,5°	72,0°

ALLROAD

	B	S	C'	D	E	F
X-TRAIL DISC						
XS	480	541	525	120	74,5°	71,0°
S	510	558	545	140	73,5°	71,0°
M	540	584	565	165	73,0°	71,5°
L	570	610	585	195	72,5°	71,5°

CROSS

	B	S	C'	D	E	F
X-NIGHT/X-NIGHT DISC						
XS	480	498	525	89	74,5°	72,0°
S	520	534	535	121	73,5°	72,0°
M	540	554	545	140	73,5°	72,0°
L	560	573	560	160	73,5°	72,0°

TIMETRIAL/TRIATHLON

	B	S	C'	D	E	F
DEAN						
XS	510	506	512	101	77,0°	72,0°
S	527	522	527	116	77,0°	73,0°
M	554	540	550	135	77,0°	73,0°
L	575	560	568	156	76,0°	73,0°

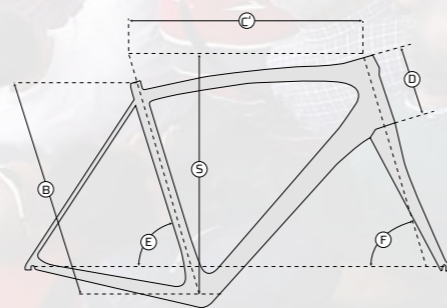

WHEELS

#BETOUGH



FULCRUM RACING ZERO
1435g



FULCRUM RACING ZERO NITE
1420g



FULCRUM RACING 3
1550g



FULCRUM RACING QUATTRO LG
1600g



FULCRUM RACING QUATTRO CARBON
1555g



FULCRUM RACING 7 LG
1765g



FULCRUM RED WIND H.50
1755g



ZIPP 303 FIRECREST CARBON
1625g



ZIPP 404 FIRECREST CARBON
1690g



ZIPP 808 FIRECREST CARBON
1915g



ZIPP 30 COURSE
1570g



DT SWISS R32 SPLINE H
1735g



DT SWISS RC 46 SPLINE H
1700g



SHIMANO RS21 BLACK
1840g



SHIMANO RS21 WHITE
1840g

DISC WHEELS

#BETOUGH



DT SWISS R23 SPLINE DISC
1655g



DT SWISS R24 SPLINE DISC
1775g



DT SWISS R32 SPLINE DISC
1720g



FULCRUM RACING QUATTRO CARBON DISC
1555g



FULCRUM RACING 5 DISC
1755g



SHIMANO RX31 DISC
1992g



ZIPP 30 COURSE DISC
1650g



SADDLES

#BETOUGH

fi'zi:k
selle
ITALIA



SELLE ITALIA SLR TI
175g



SELLE ITALIA SLS FLOW
225g



SELLE ITALIA SLR FLOW
190g



SELLE ITALIA LADY FLOW
270g



SELLE ITALIA ZOO LADY FLOW
330g



FI'ZI:K ARIONE R5 WING FLEX
220g



FI'ZI:K ARES TRI
199g



FI'ZI:K TRITONE 5.5
250g



FI'ZI:K ARIONE DONNA
WING FLEX
189g

